

SEA FROST®

148 OLD CONCORD TURNPIKE, BARRINGTON, NH 03825 USA TEL (603) 868-5720 FAX (603) 868-1040
E-Mail:sales@seafrost.com

1-800-435-6708
www.seafrost.com

SEA FROST BD 12 OR 24 VOLT XP WITH AEO AIR AND WATER COOLED SYSTEM

CONDENSING UNIT LOCATION AND MOUNTING

The water-cooling option should be considered supplemental cooling. Installation should proceed with a proper air-cooled installation first. The water-cooling feature should be used to enhance efficiency on occasions when cold-water temperatures are encountered or interior cabin air temperatures are extreme.

The design of the Sea Frost BD allows placement in an enclosed space such as a cabin locker or sail locker. Intake air should be drawn in from the cabin area to insure the coolest, driest air supply. Standard 4" duct hose may be used. Discharge may need to be vented to allow warm air to escape. Intake ducting from the exterior of the boat may cause damp salt air to be drawn in which might reduce the life of your BD. This will also increase below deck moisture. **ALLOW 1.5" CLEARANCE BETWEEN THE CONDENSER (BACK VENT AREA) AND ANY BULKHEAD TO INSURE PROPER AIRFLOW THROUGH THE CONDENSER.**

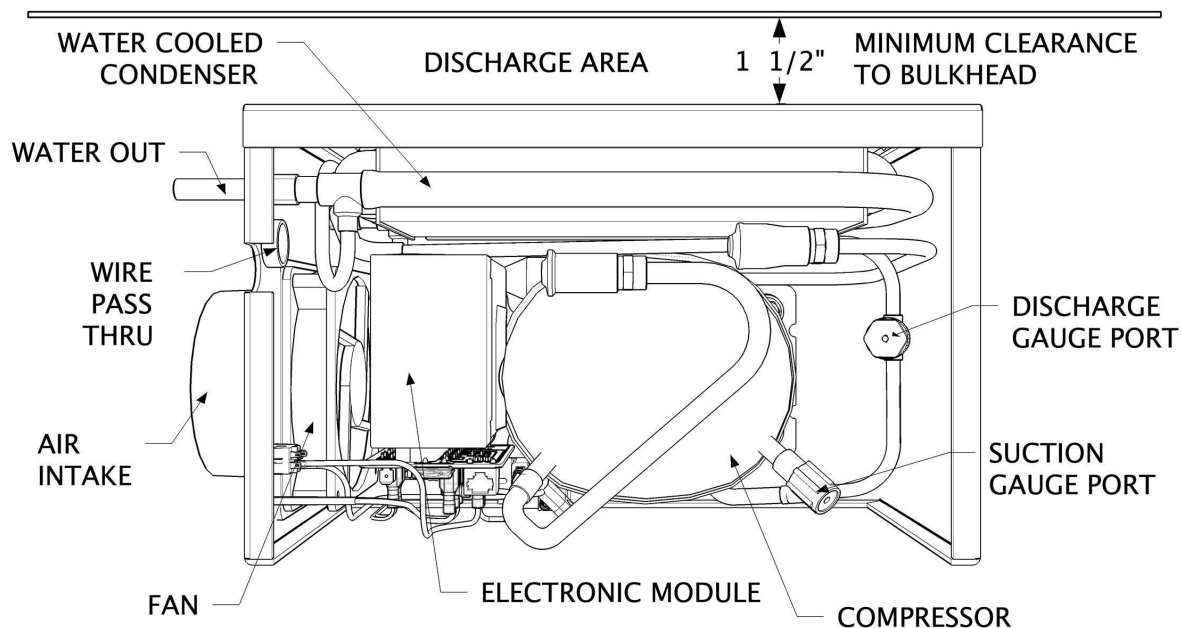

Service access and installation requires that the front, left end (inlet) and back (condenser) air outlet be exposed. A duct hose will require 4 inches of clearance past the end of the cabinet.

Mount the Sea Frost BD level, (the compressor is at the bottom). The BD may be platform mounted. Two holes have been drilled through the bottom for screw mounting to a shelf or bulkhead. If using the bulkhead mount bracket kit, follow directions supplied with the kit.

INSTALLATION REQUIREMENTS FOR CONDENSING UNIT

- Never block air inlet or outlet.
- Provide for driest, coolest air for intake.
- Total air duct length for intake should not exceed six feet.
- Make sure installation location is vented to allow warm discharge to escape.
- For intake through a finished panel, order black flange grill.

PUMP INSTALLATION

For proper operation, please understand pump installation before beginning. The BD water-cooled uses a magnetically coupled centrifugal pump. It is not self-priming and must be well below the water line. Air pockets caused by loops or descending lines from one component to the other may cause pump problems. This pump must never be run dry. It is water cooled and lubricated. The wet end may be destroyed if it is started dry. Using a different pump will defeat any energy gain.

A separate through hull fitting 1/2" or larger should be used. It should be as low in the boat as possible and away from head and cockpit drains. A forward facing scoop will prevent problems if the unit is operating underway.

A large seawater strainer should be mounted above the seacock.

The pump should be mounted horizontally. It should be higher than the strainer. The discharge should be on the top. A 3/8" hose should feed up hill to the BD unit. This should connect to the lower water fitting. From the upper water fitting a 3/8" hose should connect to a through hull above the water line. Refer to the pump installation drawing at the end of this manual.

Two or More Units on One Pump

Connect the pump to the inlet fitting on the first unit. The first unit is the lowest mounted in the boat and the connected to run the freezer. Connect the outlet to the inlet of the second unit. Connect the outlet of the second to the discharge or a third etc. Always connect the water circuit in series.

PUMP WIRING

Inside the compressor box connect the red pump wire to the (+) on the water pump relay. Connect the black wire to the (-) terminal (top row, right side) on the compressor module board. See drawing on page 10. Be sure the toggle switch is off until the boat is launched and the pump is wet.

MOUNTING A FREEZER BIN

The Sea Frost Freezer Bin mounts with a Wellnut expandable neoprene blind hole fastener. A template or the stainless steel brackets should be used to locate the mounting holes. Drill 1/4" pilot holes then increase them to 1/2".

MOUNTING THE EVAPORATOR PLATE

The plate should be mounted in the cabinet as high as possible to take advantage of thermal convection. It may be used as a shelf, mounted on the ceiling or any wall. There is no restriction as to position. Standard ice trays may be used for ice making if the plate is used as a shelf. If the plate is wall mounted a vertical ice tray kit is available. Before mounting the plate consider access to the thermostat.

The Sea Frost BD plate mounts with a Wellnut expandable neoprene blind hole fastener. A template or the plate itself should be used to locate the mounting holes. Drill a 3/16" pilot hole. Increase this hole to 3/8".

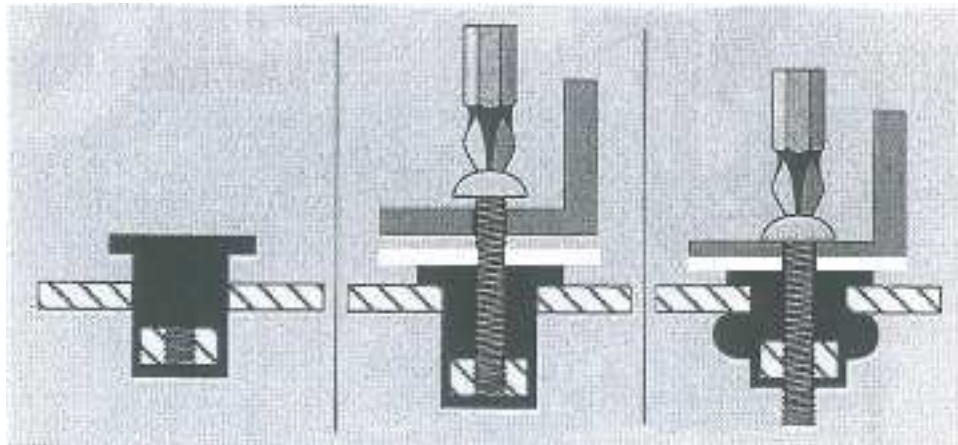

1. Place Well-nut insert all the way into Pre-drilled hole until flange is firmly against mounting surface.	2. Pass Machine screw through part to be fastened and the white spacer washer.	3. Tighten until snug.
---	--	------------------------

INSTALLING REFRIGERANT LINES

Two copper lines connect the stainless steel evaporator plate and the compressor. One is 5/16" and the other is 1/8".

Run the lines behind any and all serviceable parts. Avoid heated engine spaces. Do not coil excess tubing in an engine space. Protect the lines from being crushed, snagged or stepped on.

The quick connect fittings require a 1 inch diameter clearance hole and are staggered to allow passing through a bulkhead or insulated wall. Keep the plastic cap and shrink wrap protective cover in place until the connections are made.

WORK CAREFULLY WITH THE COPPER TUBES TO AVOID PINCHING OR KINKING THE TUBES. ALL BENDS SHOULD BE SMOOTH WITH NO LESS THAN A 2" RADIUS.

Support the tubing every 18 inches as necessary using tie wraps fastened with self-tapping screws.

Insulate at least 3' of the line set as it exits the refrigerator box. Seal both sides of the exit holes in the refrigerator box with permagum sealing compound.



WARNING:

The Sea Frost BD system is shipped pre-charged with refrigerant. This refrigerant is under some pressure. Do not fiddle with the connectors or the service ports. You might get hurt! Wear safety glasses when connecting the compressor fittings.

COMPRESSOR CONNECTIONS

The connections in the BD system are self-sealing when connecting and disconnecting. It is very important to inspect (and clean if necessary) the surfaces and "o" ring seals before assembly. If dirt, moisture, or grit, is on these connectors the system may be contaminated or the seal may be ruined.

Working with one line at a time, remove the heat shrink material and the plastic caps. Connect the larger copper line to the compressor fitting. Connect the small copper line to the remaining fitting.

Use two wrenches to tighten the fittings wrench snug. **DO NOT OVER TIGHTEN!**

WIRE SIZE

12-volt installations use AWG #10 wire for distances up to 10 feet from battery supply (20' roundtrip), and #8 AWG wire for distances up to 25 feet from battery supply (50' roundtrip). **Fuse 30 Amps.**

24 Volts: The module will self calibrate to the applied voltage and provide proper fan voltage. **Fuse 15 Amps.** The remote water pump must be a 24volt pump.

If the polarity is reversed, the electronic module will not work.
In any application, use the next largest wire if in doubt to prevent a voltage drop. A fuse is preferred over a breaker as it has less potential voltage drop.

For best performance, the electronic module must always be connected directly to the battery or battery selector switch. Connecting the module through the boat's breaker panel may cause a voltage drop; small wires and multiple connectors create resistance.

FOR PROTECTION OF THE INSTALLATION, AN EXTERNAL FUSE MUST BE INSTALLED CLOSE TO THE BATTERY IN THE POWER SUPPLY (+) CABLE.

The fuse is not provided. Connect a red wire from 12 or 24 volts positive to the (+) terminal of the terminal strip. Connect a black wire from 12 or 24 volts negative to the (-) terminal of the **line in** terminal strip. Do not operate the BDxp directly from a charger without a battery. Never apply power to any of the other terminals.

REFRIGERANT CHARGE

This system operates with refrigerant R-134a and is pre charged. The proper charge amount is 5-6 oz. An automatic expansion valve regulates the evaporator pressure. This valve is factory adjusted to maintain a constant evaporator pressure of 0 to 2 psi. Do not remove the heat shrink tubing and plastic cap or turn the knob beneath it. Technicians note: Charge amount will not affect the evaporator pressure.



WARNING! Do not use refrigerant with any additives, including but not limited to: oil, dye, and leak stop.

THERMOSTAT WIRING CONNECTIONS

Connect the thermostat wires at the compressor module to the terminals on rows C and T using 1/4" female crimp terminals. This is for AEO operation. There is no polarity requirement.

Standard BD thermostat wires ~ copper and silver.

Remote (snowflake panel) thermostat wires ~ red.
Electronic thermostat thermometer (version 1) wires ~ green and white
Electronic thermostat thermometer (version 2 & 3) cat 5 data cable with RJ 45 connector. Install a 3-amp ATC fuse in the fuse holder on the Module PCB board. **The PBC board fuse is required only if using Electronic Thermostat with the RJ-45 jack.**

STANDARD THERMOSTAT OPERATION

The thermostat is attached to the plate. The wires follow the refrigerant lines to the compressor section. Protect these wires from cuts and chafe. The BD thermostat is variable. Turning the knob fully counterclockwise turns the unit "OFF". The fully clockwise setting is the coldest. The thermostat may be adjusted to obtain any temperature desired in the cabinet and the thermostat may be calibrated should the warmest setting be too cold. To calibrate the thermostat remove the upper and lower screws on the stainless steel cover. Carefully move the stainless steel thermostat cover to reveal the white plastic cover, which is on the thermostat. Underneath the white plastic cover, locate the calibration screw.

To lower box temperature, rotate this screw counter clockwise. One full revolution will change the box temperature approximately 6 degrees F.

To raise the temperature in the box rotate the screw clockwise.

OPTIONAL REMOTE THERMOSTAT OPERATION

Slide the bulb clip onto the edge of the plate and over the sensing bulb. The sensing bulb must be in excellent thermal contact with the plate. We recommend that the probe be mounted on the plate in one of the lower mounting positions (A) as shown in the drawing below. This is best because these positions remain colder.

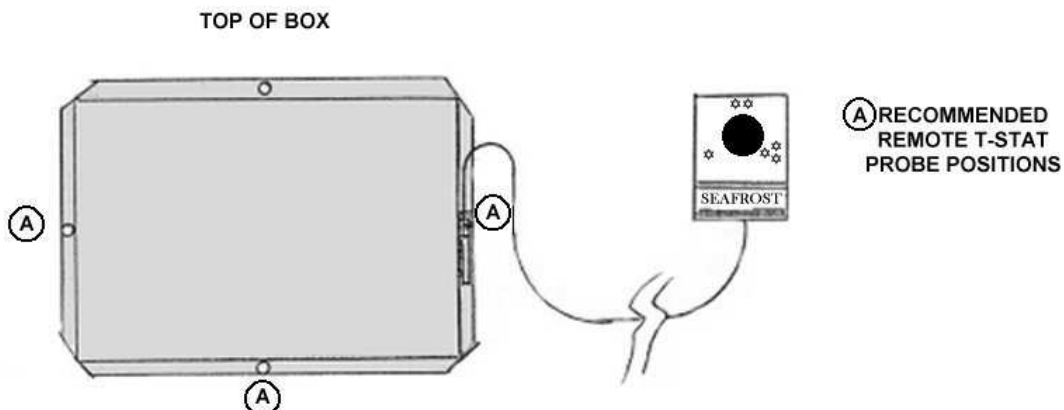
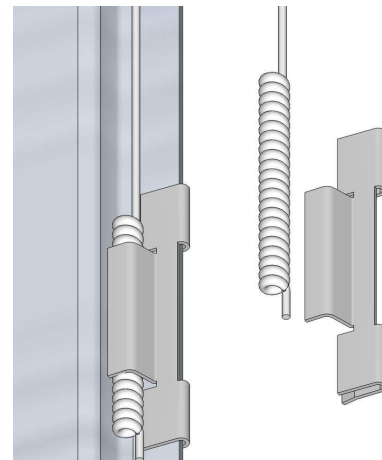

The SEA FROST BD thermostat is variable. Turning the knob fully counterclockwise turns the unit "OFF". The fully clockwise setting is the coldest. The thermostat may be adjusted to obtain any temperature desired in the cabinet. The thermostat may be calibrated should the warmest setting be too cold. To calibrate the thermostat remove the mounting screws and tip the panel forward to expose a black adjustment screw about an inch into the case.

To lower box temperature, rotate this screw counterclockwise. One full revolution will change the box temperature approximately 6 degrees F. To raise the temperature in the box rotate the screw clockwise. Make small adjustments. Record all adjustments.

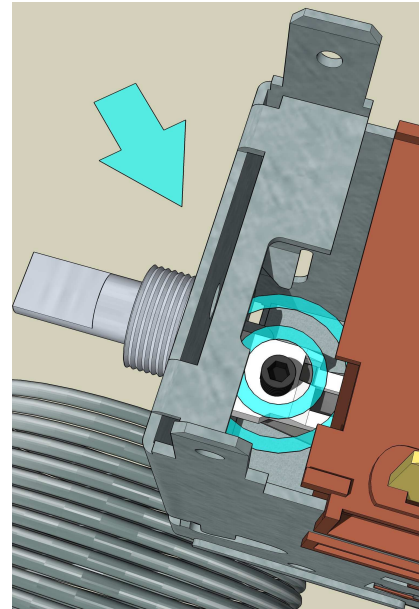

OPERATION DESCRIPTION

Once installed the BD is started by turning the thermostat clockwise from the off position. The BD will run until the plate reaches the set temperature of the thermostat. Turning the thermostat counter clockwise lowers the temperature at which the BD will switch off. The BD will remain off until the plate temperature rises about 6 degrees. (The BD is either on or off. It will not cool faster with a colder setting.)

The SEA FROST BD is a small system. It is efficient in its electrical conversion of energy to heat movement. By being small it is quiet, compact, has low electrical starting requirements and running power draw, and is able to be air-cooled. It will take some time to cool a warm cabinet.

Pump Operation

The water pump has a switch on the left end of the compressor cabinet. The on switch position for the pump is up. With the pump switch on the pump will operated automatically when the compressor starts.

You may want to switch off the pump when leaving the boat unattended. This is especially important when jellyfish, seaweed and other trash is present in the water and could block the intake sea strainer. Be sure the pump is switched off when operating the system when the boat is out of the water.

DEFROSTING

Excessive frost/ice build up on the plate will reduce the cooling effect by insulating the evaporator plate. Allowing the evaporator plate to warm above freezing is one method of defrosting. Boiling water or a scraper will also work.

OPERATION INSPECTION

Within a few minutes of starting the Sea Frost BD, the tubing in close proximity to the valve mounted on the plate and the valve itself will be noticeably cold.

IF AFTER 20 MINUTES OF OPERATION, COOLING IN THIS AREA IS NOT OBSERVED DO NOT CONTINUE TO OPERATE THE SYSTEM.

IMPORTANT: When using the water pump, check water flow and periodically inspect and clean the seawater strainer.

OPERATIONAL INFORMATION

VOLTAGE	12 D.C. or 24 D.C.
AMP/HR DRAW	3.3 to 14 @ 12 VOLTS PUMP ADDS 1 AMP/HR 2 to 7 @ 24 VOLTS
LOW VOLTAGE CUT OFF	10.4 VOLTS @ 12 VOLTS 22.8 VOLTS @ 24 VOLTS
WIRE SIZE TO BATTERY SUPPLY	AWG # 10 up to 10 FEET (20' round trip) AWG # 8 up to 25 FEET (50' round trip)
FUSE:	12 VOLT 30 AMP STANDARD AUTOMOTIVE 24 VOLT 15 AMP STANDARD AUTOMOTIVE

SERVICE NOTE: The BD is intended to operate with the cover in place. When monitoring operating with gauges, be sure to block off the top and front with cardboard and tape to maintain proper airflow to the condenser.

WATER COOLED MAINTENANCE

Drain all water from the pump, sea strainer, hoses and water coil in the BD housing when entering a freezing climate. Switch off the pump to avoid dry pump operation.

Periodically inspect and clean the seawater strainer.

TROUBLESHOOTING

A light emitting diode (LED) is connected between terminals **+** and **D**. In case the electronic unit records an operational error, the diode will flash a number of times. The number of flashes depends on what kind of operational error was recorded. Each flash lasts 1/4 second. After the actual number of flashes there will be a delay with no flashes, the sequence for each error recording is repeated every 4 seconds. Flashes will only occur in the fault mode with the system on.

See additional trouble shooting information available at www.seafrost.com

OPERATIONAL ERRORS SHOWN BY LED

Number of flashes	Error type
5	Thermal cut-out of electronic unit (If the refrigeration system has been too heavily loaded, or if the ambient temperature is high, the electronic unit will run too hot).
4	Minimum motor speed error (If the refrigeration system is too heavily loaded, the motor cannot maintain minimum speed 1,850 rpm).
3	Motor start error A. (The system might be overcharged.) Has charge been added? B. Faulty module. C. This fault may also occur when the compressor is trying to start a warm system or on initial start up on a new system. Several attempts and then start up can be normal. <i>Do not let out refrigerant until first contacting Seafrost!</i>
2	Fan over-current cut-out (The fan is defective).
1	Battery protection cut-out (The voltage is outside the cut-out setting. Low voltage.)

BD XP Air-Water Wiring

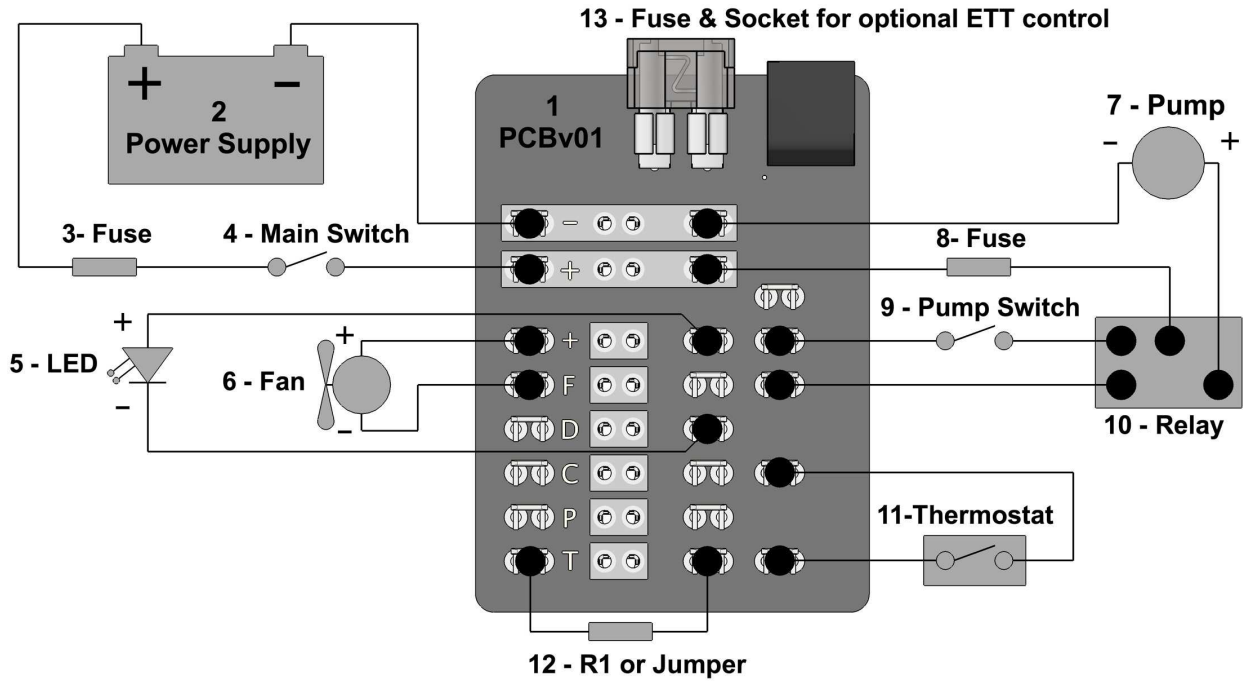

NOTE: When using the modular thermostat connection (#13) there are no connections on thermostat terminals (#11).

<ul style="list-style-type: none"> 1. Electronic unit 2. Battery 3. Fuse (see electrical connections) 4. Main switch (optional) 5. LED for operational errors 6. Fan 7. Pump 8. Fuse 	<ul style="list-style-type: none"> 9. Pump Switch 10. Relay 11. Thermostat 12. R1- Resister for pre-setting speed (optional) or Jumper for AEO module 13. RJ45 jack for optional Electronic Thermostat.
--	--

NOTE

1. THE PUMP IS NOT SELF-PRIMING.
MOUNT BELOW THE WATERLINE.
2. THE PUMP MUST BE MOUNTED ABOVE
THE STRAINER AND THRU HULL.
3. ARRANGE COMPONENTS SO AIR
CANNOT BE TRAPPED IN LINES.

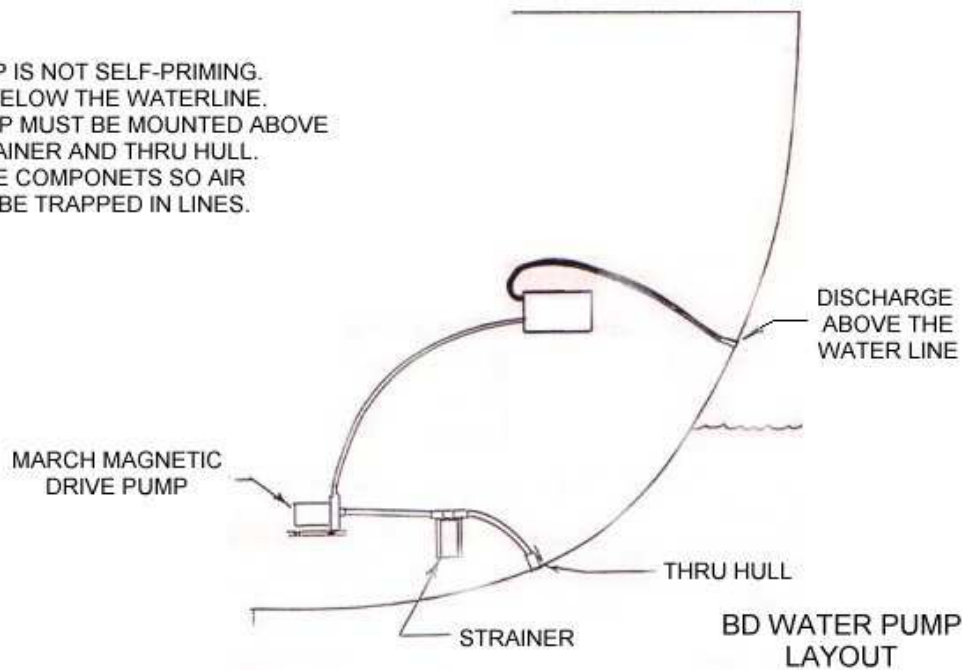

Our Repair Policy

Your **Sea Frost BD** system is manufactured to the highest standards and thoroughly tested. If you experience problems with your system requiring technical service, return it to us freight prepaid.

When a system is returned to us we will fix manufacturing defects and failures occurring in normal operation for one year from the date of purchase or from the date of first usage/commissioning at no charge, and return it to you freight prepaid (surface freight) anywhere in the continental United States. Installation damage and damage to the electrical parts will be favorably considered however this damage is not our responsibility.

Improper wiring, improper voltage, corrosion, and water damage are not considered manufacturing defects. It is your job to install and maintain your system in a reasonable manner to prevent possible problems.

Proper installation and reasonable care will give you many years of excellent operation. Please notify us before returning your system for repair.

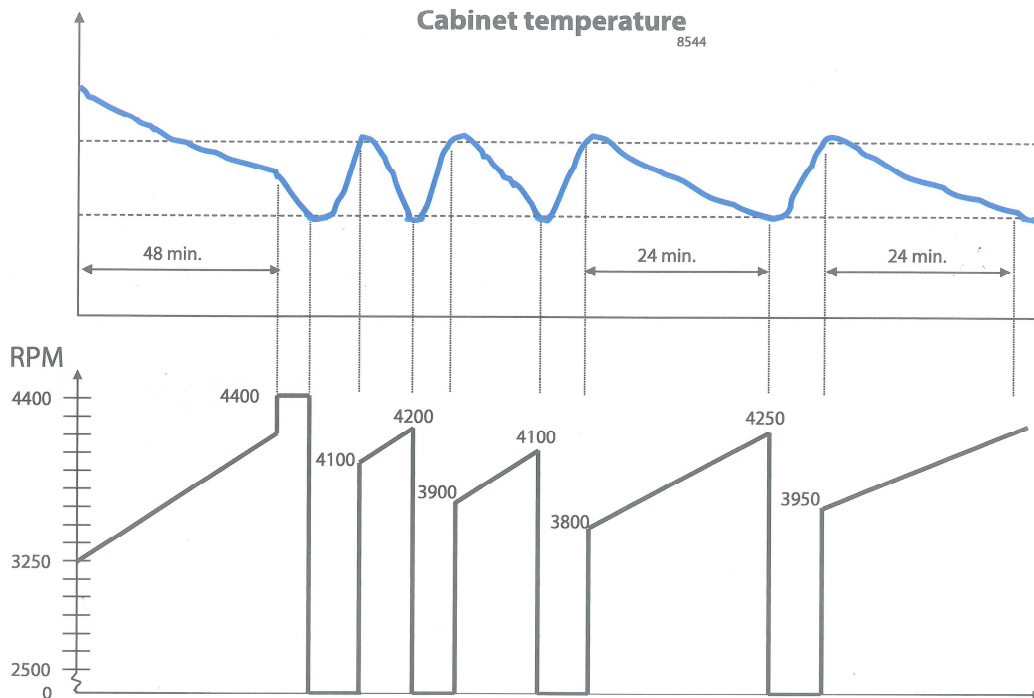

Adaptive Energy Optimization (AEO) with High Speed Electronit Unit

Introduction

Herewith a description of a function in the high speed electronic unit. The unit contains a feature called **Adaptive Energy Optimization (AEO)**. It is very suitable for systems with huge load variations and applications where energy is an important issue.

Function

Initial start up conditions

Every start up of the compressor takes place at low speed (soft start). The start up speed is equal to: the speed at thermostat cut out minus 300 rpm. After start up the speed of the compressor will be ramped up and adapted to the load. The ramp up speed is 9.4 rpm/min.

Adaptation of the capacity.

The software algorithm adapts the capacity of the compressor to the actual load of the system.

The unit regulates the capacity so that the compressor runtime is approximately 24 minutes. If the compressor does not reach cut out temperature within 48 minutes the speed is set to 4400 rpm.

Example how to determine the speed

Start up speed: 3250 rpm
 Runtime: 15 minutes
 Speed at cut out: $3250 + (9.4 \times 15)$
 ~3390 rpm

Start up speed: $3390 - 300 = 3090$ rpm
 Runtime: 20 minutes
 Speed at cut out: $3090 + (9.4 \times 20)$
 ~3280 rpm

Start up speed: $3280 - 300 = 2980$ rpm
 Runtime: 30 minutes
 Speed at cut out: $2980 + (9.4 \times 30)$
 ~3260 rpm

Curves

The graphs on page 2 show the relation between cabinet temperature and speed. After a power cut out the start speed will always be set to 3250 rpm.

After a thermostat cut out the start up speed is calculated as speed at stop minus 300.

The speed will be adapted automatically so that the thermostat runtime will be approximately 24 minutes.

Benefits

- Independent of load variations
- Energy savings
- Reduced number of compressor starts
- Prevents short cycling of the compressor
- Battery protection
- Soft start in tropical conditions